

CL-360XR and CL-360HD

NEW

360-Degree Long-Range Survey Grade Lidar Scanner

The CL-360 delivers optimal survey-grade lidar sensor performance for use in the highest accuracy airborne, uav or mobile applications. The CL-360 features long-range detection of low-reflectance targets, survey-grade accuracy and precision, industry leading scanner speed for appealing point distribution, tight laser beam divergence for vegetation penetration and high definition point registration in a reliable and compact form-factor.

The CL-360XR is designed for airborne applications where long-range detection and vegetation penetration performance is demanded. The CL-360HD is designed for UAV and mobile applications where point density, precision and value are key requirements. Both the CL-360XR and CL-360HD share common hardware and software interfaces.

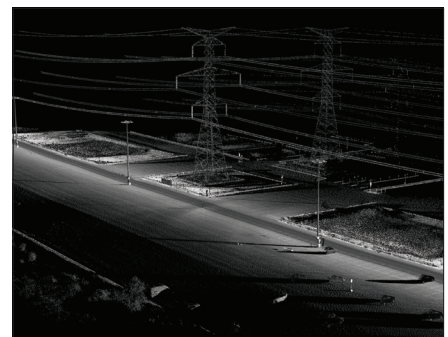
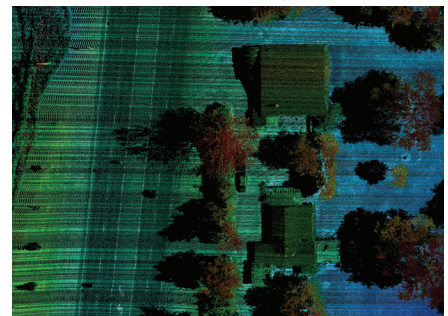
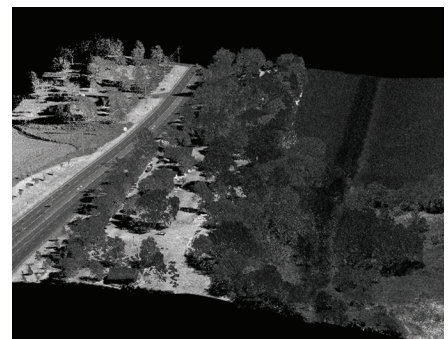

CL-360XR and CL-360HD

Technical Specifications

NEW

Parameters	CL-360XR			CL-360HD	
	50 kHz	200 kHz	500 kHz	200 kHz	500 kHz
LASER PULSE REPETITION FREQUENCY (PRF)					
Max Range Capacity ¹					
@ 10% target reflectivity	610 m	310 m	195 m	205 m	130 m
@ 20% target reflectivity	750 m	435 m	250 m	290 m	185 m
@ 50% target reflectivity	750 m	740 m	250 m	490 m	250 m
Typical Operating Altitude ²					
@ 10% target reflectivity	390 m	195 m	125 m	130 m	85 m
@ 20% target reflectivity	480 m	275 m	160 m	185 m	120 m
@ 50% target reflectivity	480 m	470 m	160 m	315 m	160 m
Range Accuracy, 1sigma ¹	10 mm	5 mm	5 mm	5 mm	5 mm
Range Precision, 1sigma ¹	4 mm	4 mm	4 mm	4 mm	4 mm
LASER					
Wavelength	1550 nm				
Laser Safety Classification	1				
Beam Divergence (1/e ²)	0.3 mrad				
Beam Footprint at 1/e ²	8.1 mm @ 5 m, 8.5 mm @ 10 m, 11 mm @ 25 m, 17 mm @ 50 m, 31 mm @ 100 m				
RETURNS					
Range Measurement Principle	Time of Flight				
Sample Collection Rate	Up to 2 Mhz				
Intensity Measurement	12bits raw measurement, >16 bits normalized for range				
Minimum Range	1.5 m				
Number of Returns	Up to 4 (first 2 and last 2)				
Range Resolution	2 mm				
Minimum Target Separation	0.7 m (discrete)				
SCANNER					
Field of View	360 deg				
Scan Speed	50-250 lines/second				
Angular Step Width	0.036 – 1.8 deg				
Angular Measurement Resolution	0.001 deg				
GENERAL					
Input Voltage	11-36 V				
Power (Typical)					
@ 100 Hz Scan Speed	35 W				
@ 200 Hz Scan Speed	38 W				
@ 250 Hz Scan Speed	40 W				
ENVIRONMENTAL					
Operating Temperature ⁴	-10° C to +40° C				
Storage Temperature	-20° C to +50° C				
Ingress Protection	IP67				
Vibration	DO-160H Section 8, Category S, Curve M				
Shock	DO-160H Section 7, Category A, Standard Shock				
Weight	3.5 kg				
Dimensions	310 mm L x 160 mm W x 116 mm H				
INTERFACES					
Connector 1	Power, PPS, NMEA (\$GPZDA)				
Connector 2	1 GigE Ethernet for realtime data and control				
Data Storage	240 GB				
API	REST, UDP, Windows (Intel x86-64), Linux (Intel x86-64)				

1. Teledyne Optech Test Conditions, contact for details.

2. Nadir +/- 45 deg field of view, +/- 5 deg roll.

3. Target size >= laser footprint, perpendicular angle of incidence, 23 km clear visibility.

4. Maximum +50° C case temperature. Airflow necessary over heatsink fins to ensure case temperature not exceeded.



Class 1 Laser Product

CL-360XR and CL-360HD

Range Performance and Airborne Point Density

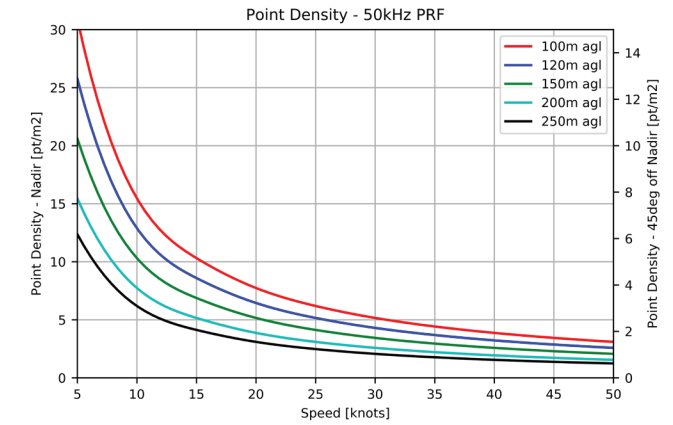
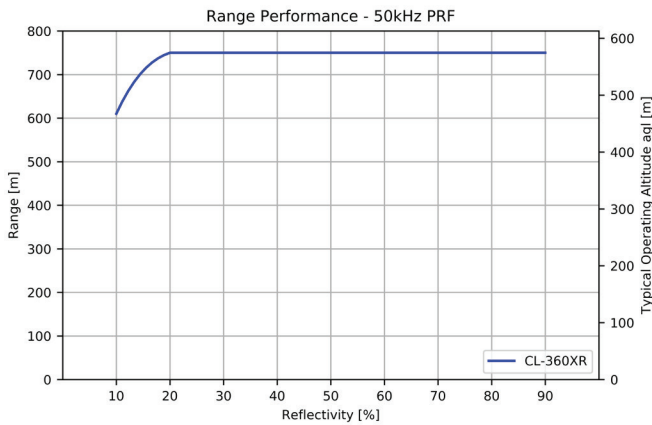
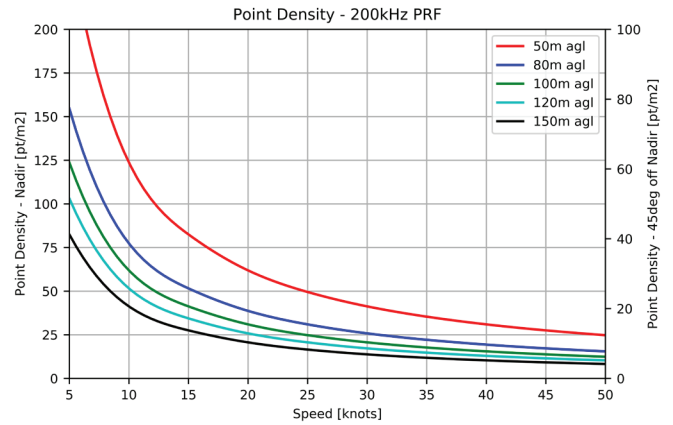
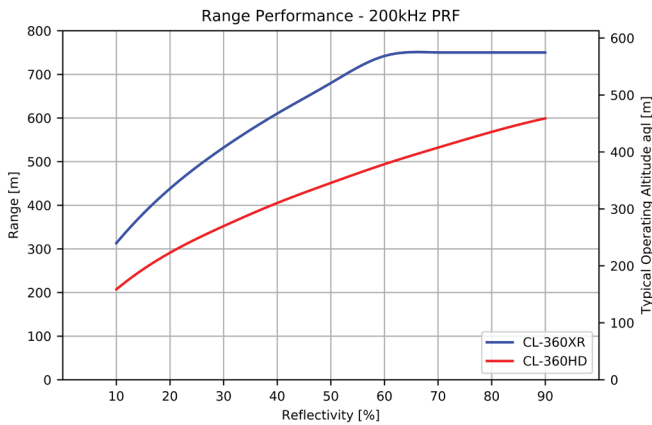
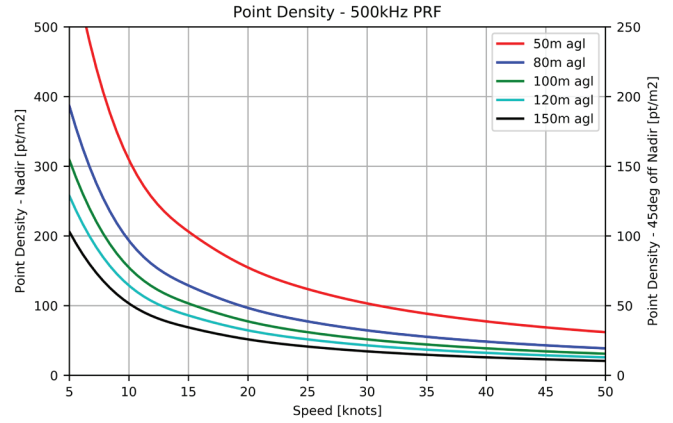
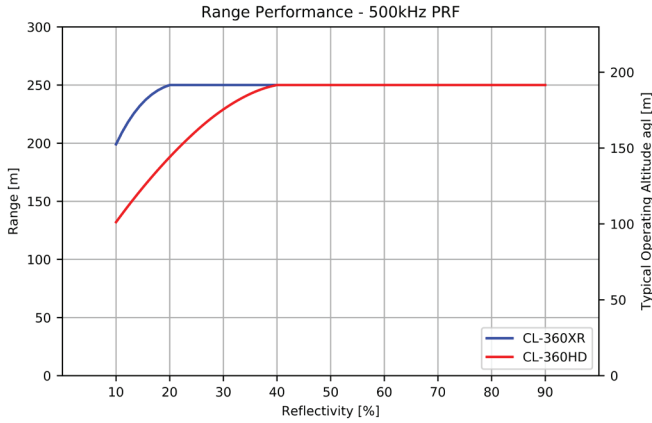

CL-360XR and CL-360HD

Mobile Scan Pattern—Single Scanner²

Transversal Distance	Vehicle Speed								
	40 kph			50 kph			60 kph		
	RLongitudal (mm)	RTransversal (mm)	Density (pt/m ²)	RLongitudal (mm)	RTransversal (mm)	Density (pt/m ²)	RLongitudal (mm)	RTransversal (mm)	Density (pt/m ²)
0 m	44	13	1748	56	13	1374	67	13	1148
2 m	44	16	1420	56	16	1116	67	16	933
10 m	44	88	258	56	88	203	67	88	170
20 m	44	314	72	56	314	57	67	314	48

2. 500 khz PRF, 250 lines/second, 3 m height above ground, 45 deg pitch angle, longitudinal direction is in the direction of vehicle travel in the ground plane, transversal direction is perpendicular to vehicle travel in the ground plane.

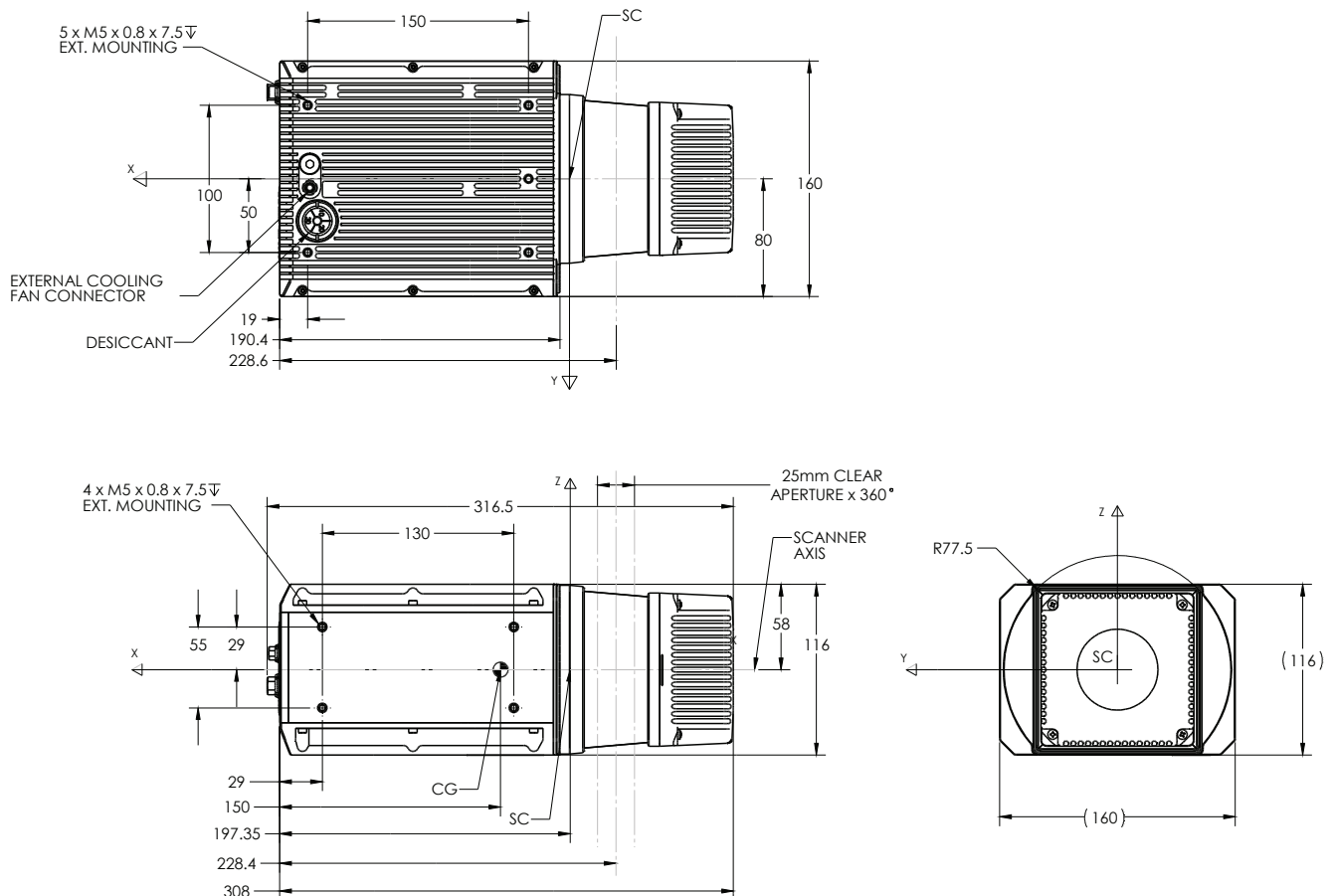

www.teledynegeospatial.com



Canadian Space Agency / Agence spatiale canadienne
This program is undertaken with the financial support of the Canadian Space Agency.

2022 © Teledyne Optech. E6OE. Information subject to change without notice. Teledyne CARIS and Teledyne Optech are part of Teledyne Technologies Ltd.

Revision Date: 2022 06 07

Teledyne Geospatial
Imaging Solutions for Land and Water

